



**AVERY  
DENNISON**

Fastener  
Solutions

# **Super Heavy Duty Fasteners Marketing Specifications**

For the following part numbers:

10575-0

10576-0

10577-0

10578-0

10579-0

August 1, 2018

# AVERY DENNISON MARKETING SPECIFICATION

TOLERANCES IN. = ± .030 IN.  
MM = ± 0.7 mm

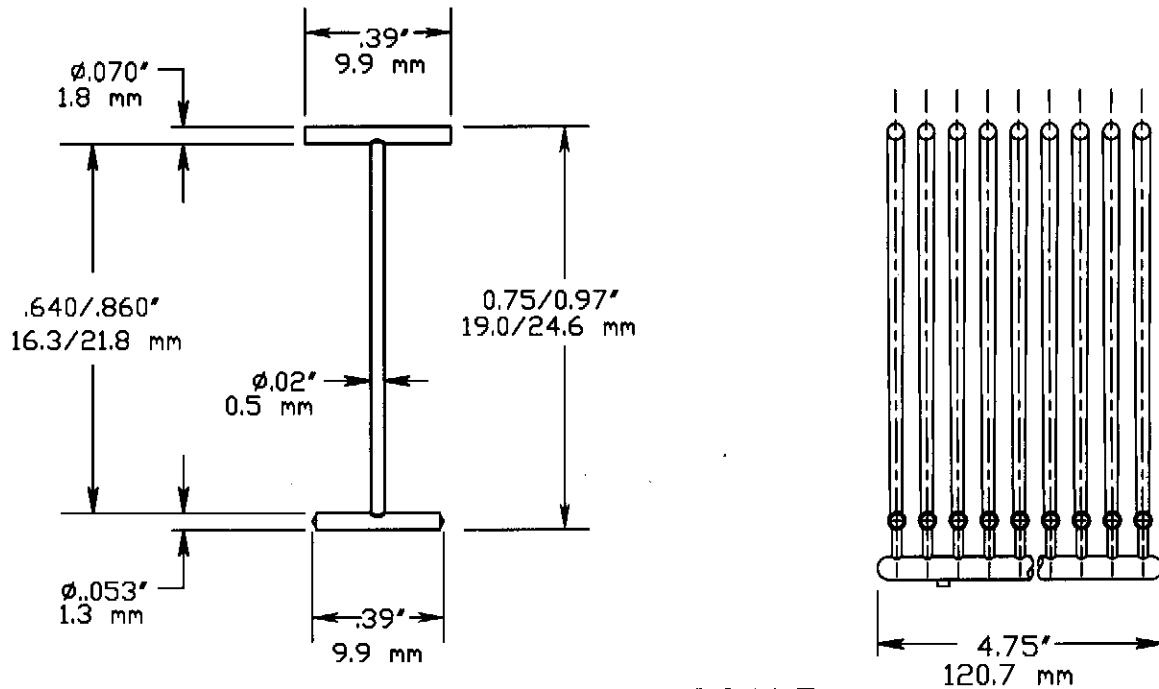

NOT TO SCALE

NOMINAL TENSILE STRENGTH:	10/11 LBSF. / 4.5/5.0 KGF.
MATERIAL:	NYLON, TYPE 6 - NATURAL
WEIGHT/FASTENER:	.00190 oz. / .056 grams
CLIP QUANTITY:	50
APPLICATION TOOL:	10637 STANDARD PISTOL-GRIP MARK II HAND TOOL (CONTACT LOCAL SALES PERSON FOR INFORMATION ON POWERED EQUIPMENT)
PACKAGED IN:	5,000/CTN., 50,000/CASE
T/F CONN. PADDLES	YES



FASTENER DIVISION  
FITCHBURG, MA 01420 U.S.A.  
TEL. 1-800-225-5813  
FAX. 1-800-848-2169

DESCRIPTION:

3/4" (19mm) Swiftach® SHD T-End

APPROVAL:

*[Signature]* 1-30-09

STOCK NO.

10575

REV  
F

# AVERY DENNISON MARKETING SPECIFICATION

TOLERANCES IN. = ± .030 IN.  
MM = ± 0.7 mm

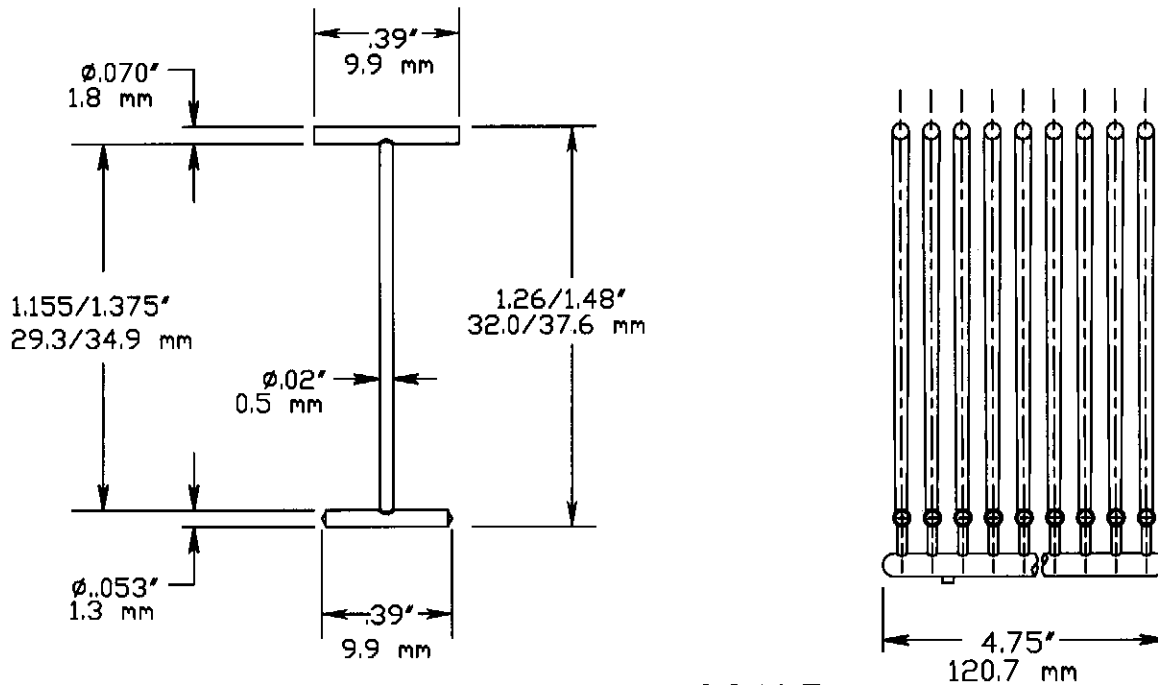

NOT TO SCALE

NOMINAL TENSILE STRENGTH:	10/11 LBSF. / 4.5/5.0 KGF.
MATERIAL:	NYLON: TYPE 6 - NATURAL
WEIGHT/FASTENER:	.00218 oz. / .064 grams
CLIP QUANTITY:	50
APPLICATION TOOL:	10637 STANDARD PISTOL-GRIP MARK II HAND TOOL (CONTACT LOCAL SALES PERSON FOR INFORMATION ON POWERED EQUIPMENT)
PACKAGED IN:	5,000/CTN., 50,000/CASE
T/F CONN. PADDLES	YES



FASTENER DIVISION  
FITCHBURG, MA 01420 U.S.A.  
TEL. 1-800-225-5913  
FAX. 1-800-848-2169

DESCRIPTION:

1-1/4" (32mm) Swiftach® SHD T-End

APPROVAL:

*[Signature]* 1-30-09

STOCK NO.

10576

REV  
H

# AVERY DENNISON MARKETING SPECIFICATION

TOLERANCES IN. =± .030 IN.  
MM =± 0.7 mm

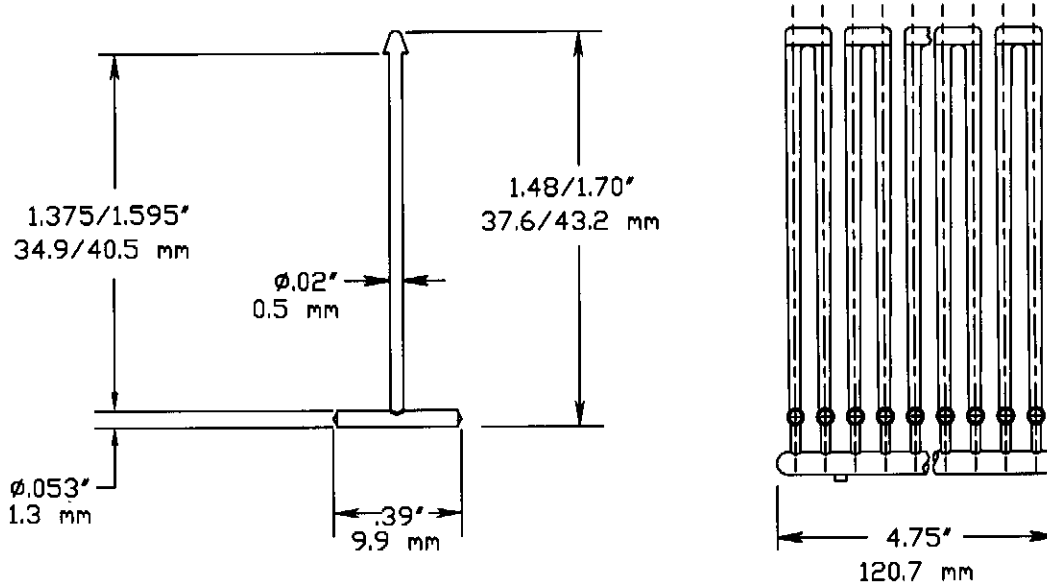

NOT TO SCALE

NOMINAL TENSILE STRENGTH:	10/11 LBSF. / 4.5/5.0 KGF.
MATERIAL:	NYLON; TYPE 6 - NATURAL
WEIGHT:	.081 GRAMS PER FASTENER
CLIP QUANTITY:	25
APPLICATION TOOL:	10637 STANDARD PISTOL-GRIP MARK II HAND TOOL (CONTACT LOCAL SALES PERSON FOR INFORMATION ON POWERED EQUIPMENT)
PACKAGED IN:	5000/CTN, 50,000/CASE
T/F CONN. PADDLES:	NO



FASTENER DIVISION  
FITCHBURG, MA 01420 U.S.A.  
TEL. 1-800-225-5913  
FAX. 1-800-848-2169

DESCRIPTION:

1-1/2" (38mm) SHD Loop

APPROVAL:

*[Signature]* 1-30-09

STOCK NO.

10577

REV

H

# AVERY DENNISON MARKETING SPECIFICATION

TOLERANCES IN. =± .030 IN.  
MM =± 0.7 mm

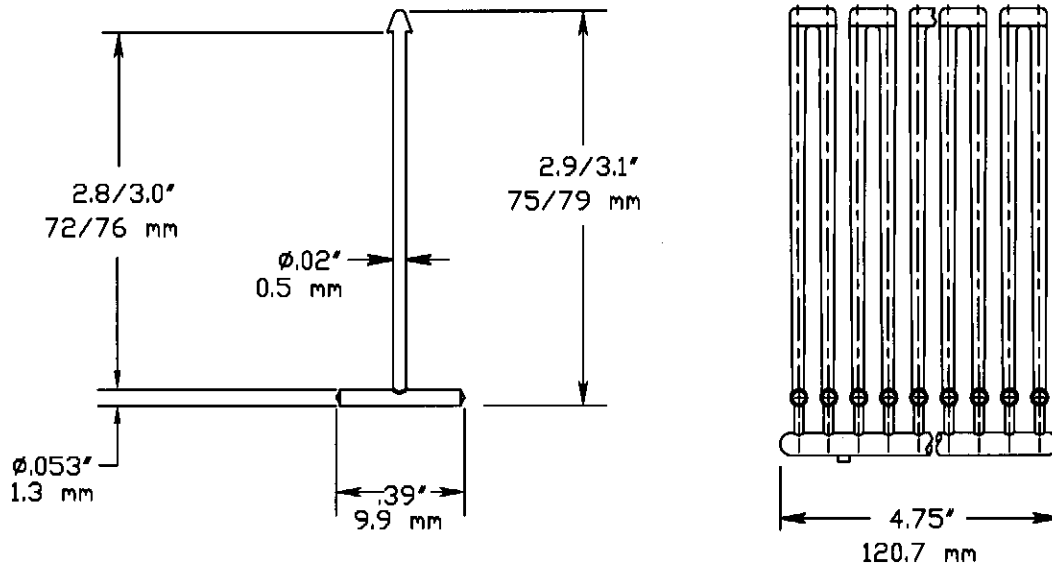

NOT TO SCALE

NOMINAL TENSILE STRENGTH:	10/11 LBSF. / 4.5/5.0 KGF.
MATERIAL:	NYLON; TYPE 6 - NATURAL
WEIGHT:	.124 GRAMS PER FASTENER
CLIP QUANTITY:	25
APPLICATION TOOL:	10637 STANDARD PISTOL-GRIP MARK II HAND TOOL (CONTACT LOCAL SALES PERSON FOR INFORMATION ON POWERED EQUIPMENT)
PACKAGED IN:	5000/CTN, 50,000/CASE
T/F CONN. PADDLES:	NO



FASTENER DIVISION  
FITCHBURG, MA 01420 U.S.A.  
TEL. 1-800-225-5913  
FAX. 1-800-848-2169

DESCRIPTION:  <p style="text-align: center;">3" (74mm) SHD Loop</p>	APPROVAL:  1-30-09	
	STOCK NO.  <p style="text-align: center;">10578</p>	REV  <p style="text-align: center;">G</p>

# AVERY DENNISON MARKETING SPECIFICATION

TOLERANCES IN. =± .030 IN.  
MM =± 0.7 mm

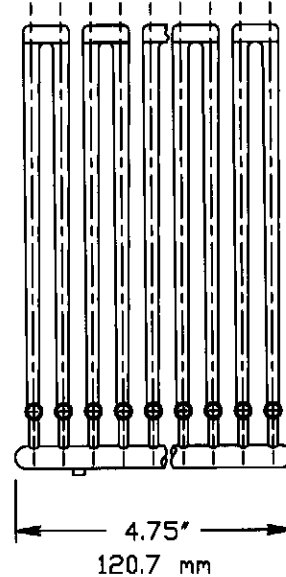
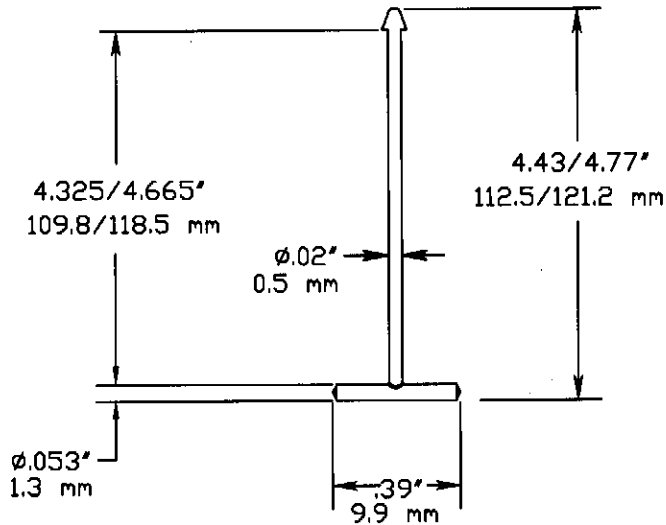

NOT TO SCALE

NOMINAL TENSILE STRENGTH:	10/11 LBSF. / 4.5/5.0 KGF.
MATERIAL:	NYLON: TYPE 6 - NATURAL
WEIGHT:	.124 GRAMS PER FASTENER
CLIP QUANTITY:	25
APPLICATION TOOL:	10637 STANDARD PISTOL-GRIP MARK II HAND TOOL (CONTACT LOCAL SALES PERSON FOR INFORMATION ON POWERED EQUIPMENT)
PACKAGED IN:	5000/CTN, 50,000/CASE
T/F CONN. PADDLES:	NO



FASTENER DIVISION  
FITCHBURG, MA 01420 U.S.A.  
TEL. 1-800-225-5913  
FAX. 1-800-848-2169

DESCRIPTION:

4-1/2" (114mm) SHD Loop

APPROVAL:

*[Signature]* 1-30-09

STOCK NO.

10579

REV

G